

BAHNHOF »SCHWARZBURG«



»SCHWARZBURG« STATION

GARE DE »SCHWARZBURG«

STATION »SCHWARZBURG«

Art. Nr. 110116

D

Vor Beginn des Bastelns sollten Sie sich mit den Spritzlingen und der Anleitung vertraut machen. Sollte es einmal vorkommen, dass ein Teil im Bausatz fehlt, kreuzen Sie bitte das fehlende Teil in der Anleitung an und schicken Sie diese bitte an Fa. Gebr. FALLER GmbH, Abt. Kundendienst, kundendienst@faller.de, Kreuzstraße 9, 78148 Gütenbach. Sie erhalten dann umgehend Ersatz. In diesem Bausatz sind einige Kunststoffteile übrig.

GB

Before beginning with the assembly please familiarize yourself with the parts and read the instructions carefully. In case of missing parts please indicate these on the instructions leaflet with a circle and return the leaflet to Gebr. FALLER GmbH, kundendienst@faller.de, Kreuzstraße 9, D-78148 Gütenbach, Germany. You will receive the replacement by return. Some of the parts in this box are not needed to construct the model.

F

Avant de commencer le montage de votre maquette bien lire la notice et repérer les grappes. Si une pièce manque dans une boîte, cochez la pièce correspondante sur la notice et renvoyez-la-nous à Gebr. FALLER GmbH, kundendienst@faller.de, Kreuzstraße 9, D-78148 Gütenbach (R.F.A.). Nous vous ferons parvenir la pièce par retour. Dans cette boîte se trouvent quelques pièces qui ne seront pas utilisées pour le montage.

NL

Vóór het bouwen zou men de gietsukken en de handleiding moeten bestuderen. Indien onverhoopt een onderdeel aan het bouwpakket ontbreekt, gelieve men het ontbrekende deel in de handleiding aan te kruisen en deze te zenden aan Gebr. FALLER GmbH, kundendienst@faller.de, Kreuzstraße 9, D-78148 Gütenbach. U ontvangt dan omgaand en gratis het ontbrekende onderdeel. Van dit bouwpakket worden enkele kunststof delen niet gebruikt.

Für den Zusammenbau des Modells empfehlen wir folgende FALLER-Artikel (sind nicht im Bausatz enthalten):
For the assembly of the kit we recommend following FALLER products (not included in the kit):
Pour l'assemblage du modèle, nous vous recommandons les articles FALLER suivants (non inclus dans le kit):
Om dit model te bouwen adviseren wij de volgende FALLER producten (maken geen deel uit van deze bouwset):



Art. Nr. 170492
FALLER-EXPERT

Flüssigkleber in Plastikflasche mit Spezialkanüle für Feinste Klebstoffdosierung.

Liquid cement in plastic bottle with canule for very fine dosage.

Colle liquide en bouteille plastique avec bec verseur pour un dosage précis.

Vloeibare lijm in plastic-flescon met doseerbuisje om nauwkeurig te lijmen.



Art. Nr. 170688
SPEZIAL-SEITENSCHNEIDER

zum gratfreien Abtrennen von feinsten Spritzteilen.
Nur für Polystyrol geeignet.

Special side cutter for cutting off ultra-fine moulded parts without burrs. Only suitable for polystyrene.

Pince coupante spéciale pour couper sans bavure les pièces miniatures moulées par injection. Convient uniquement au polystyrène.

Speciale zijknipsang voor het braamloos afknippen van de fijnste gietsukdelen. Alleen geschikt voor polystyrol.



Inhalt	Spritzlinge	1	1	x	4	1	x	7	1	x	10	1	x	13	1	x
Contents	Sprues	2	1	x	5	1	x	8	1	x	11	1	x	14	1	x
Contenu	Moulages	3	1	x	6	1	x	9	1	x	12	1	x			
Inhoud	Gietsukken															

Sa. Nr. 199 275 0

- D Fensterfolie**
Fensterfolie entlang der vorgeprägten Rillen exakt ausschneiden.
Die Folienschnitte auf die Rückseite der Fenster bzw. Türen mit derselben Nr. kleben.

- GB Window foil**
Cut out the window foil along the prepared grooves exactly.
Glue the cut out foil parts on the back side of the windows resp. doors with the same number.

- F Feuillet transparent**
Découper la feuille des fenêtres en suivant les marques prévues à cet effet.
Puis emboîter et coller ensemble les deux parties des portes et fenêtres.

- NL Vensterfolie**
Knip het raam folie precies langs de aangegeven lijnen uit.
Lijm de uitgeknipte delen op de achterzijde van de ramen resp. deuren met hetzelfde nummer.

Modell ist beleuchtbar mit 3 Micro-Kabelbirnen Art. Nr. 180671.
Modell ist beleuchtbar mit 1 Beleuchtungssockel Art. Nr. 180670.

The model can be illuminated using 3 micro-bulbs No.180671.
The model can be illuminated using 1 building light No. 180670.

Cette maquette s'éclaire avec 3 ampoules microcables ref. 180671.
Cette maquette s'éclaire avec 1 socle d'éclairage ref. 180670.

Model kan worden verlicht met 3 micro draadlamjes nr. 180671.
Model kan worden verlicht met 1 fitting met lampje nr. 180670.

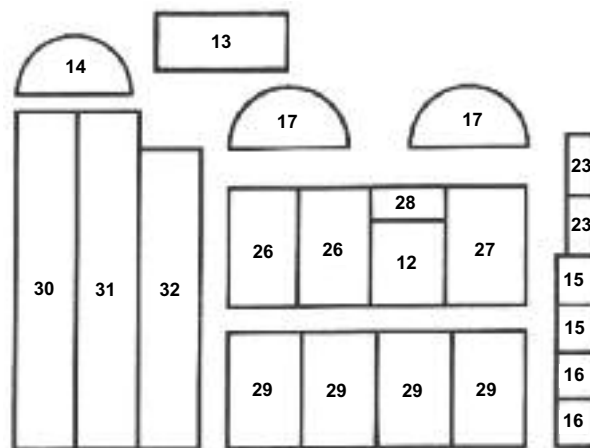
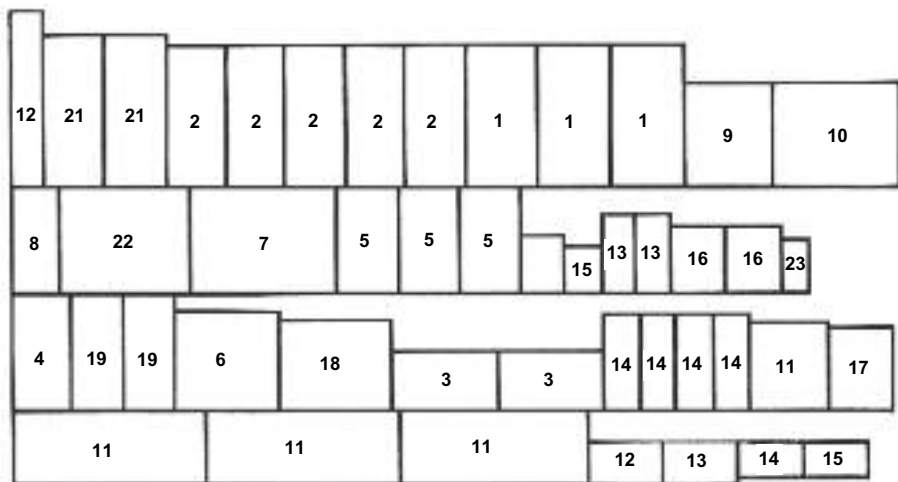

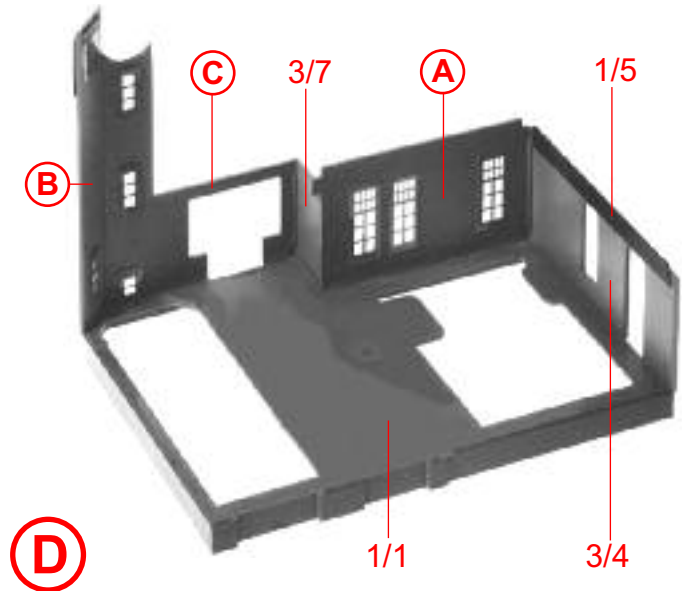
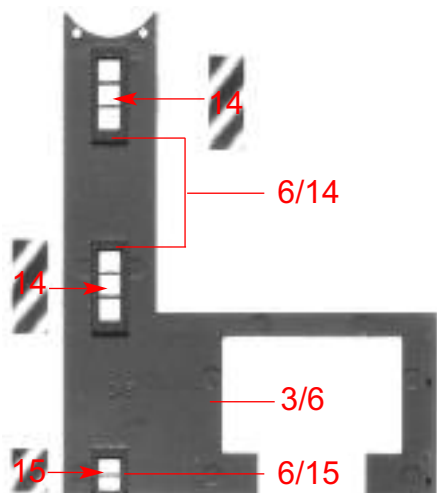
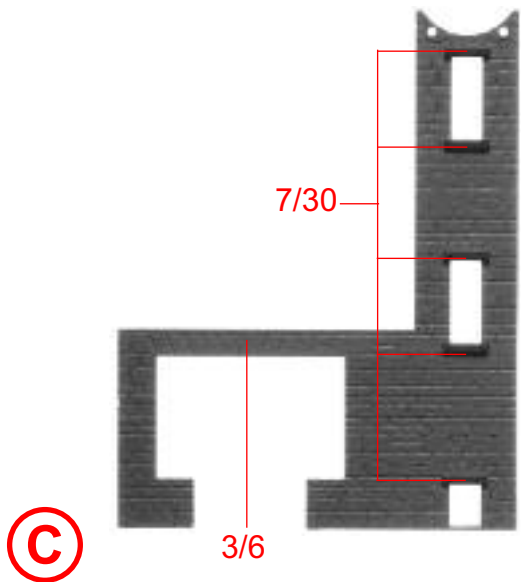
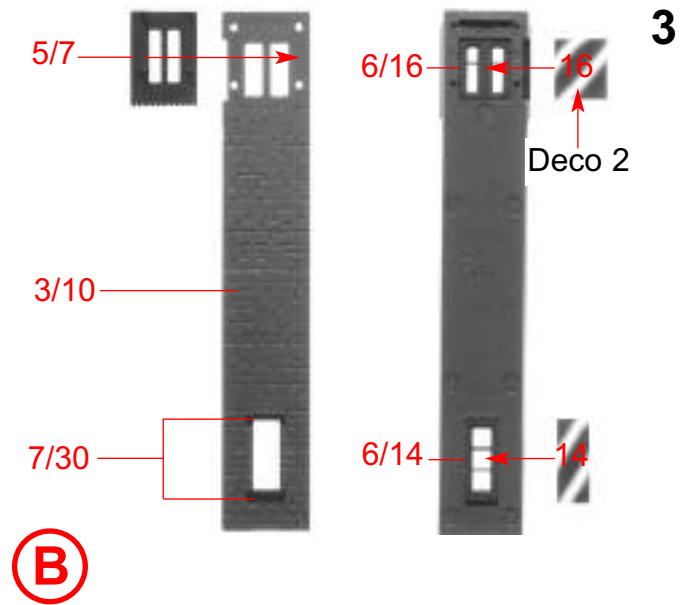
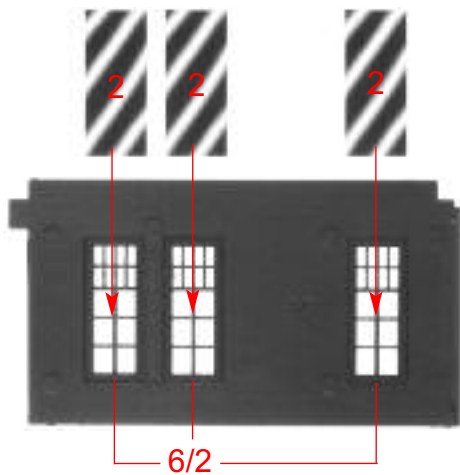
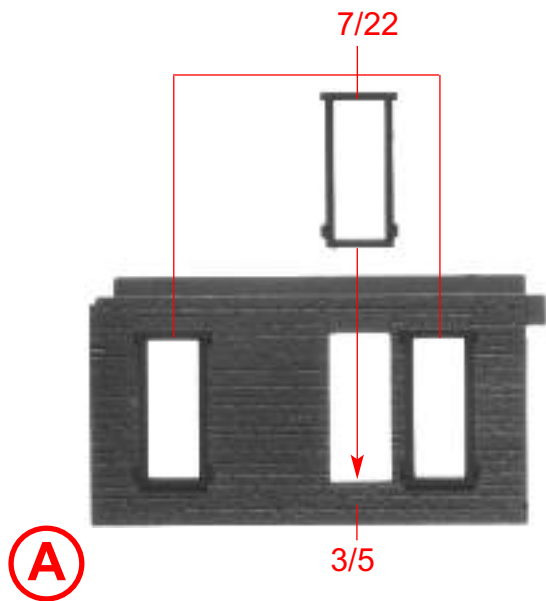

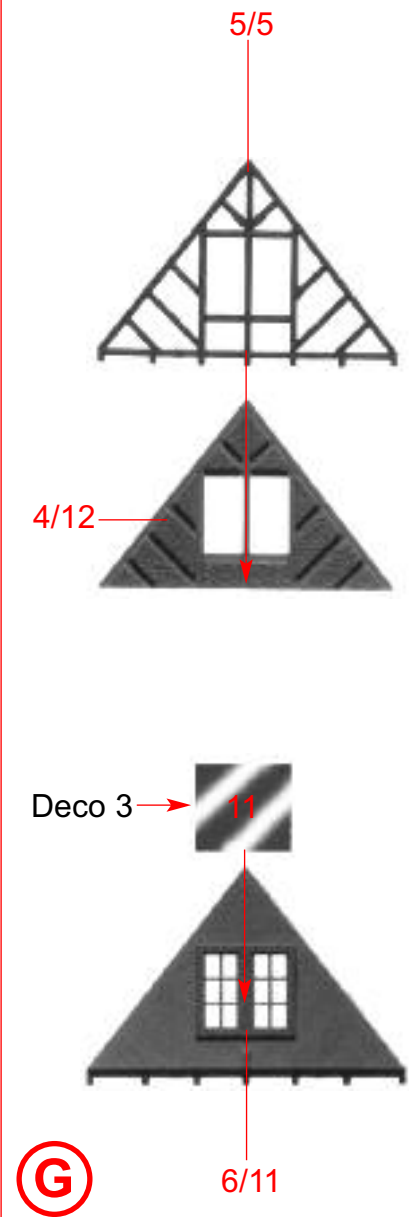
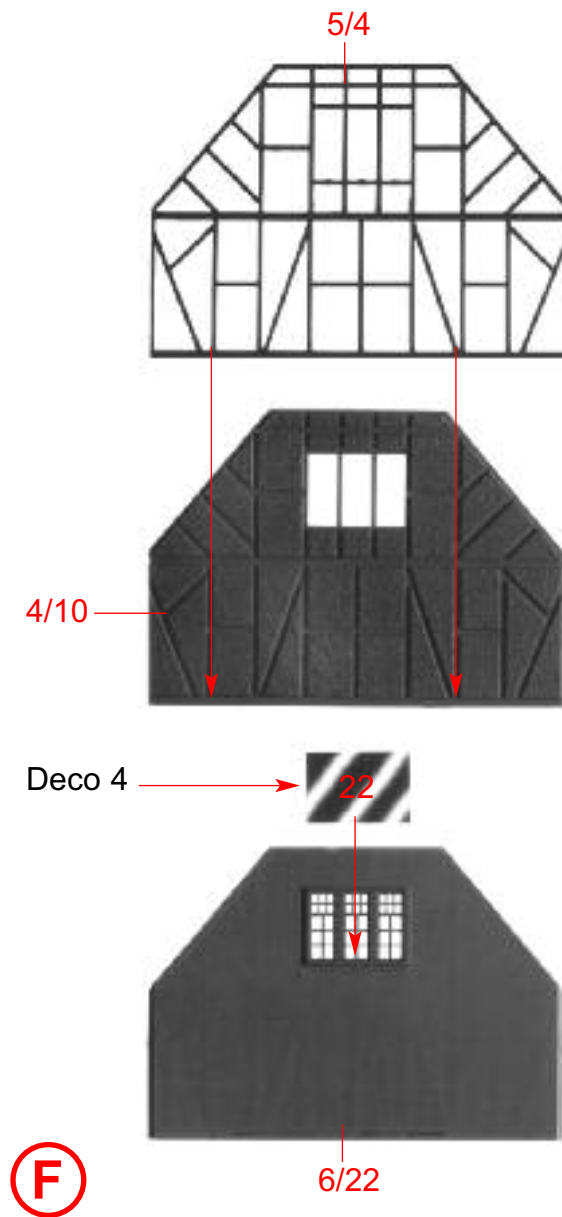
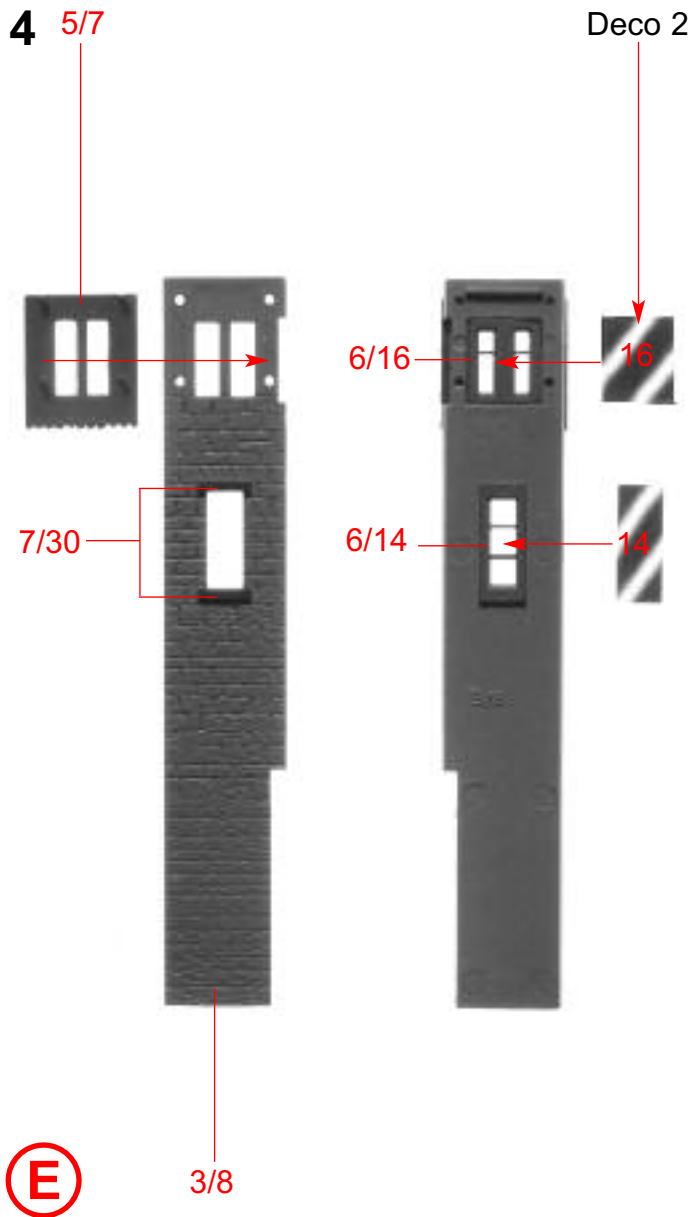

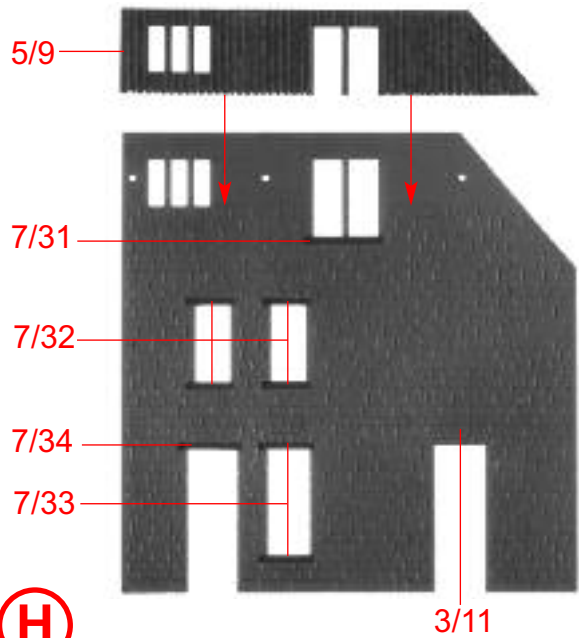

H

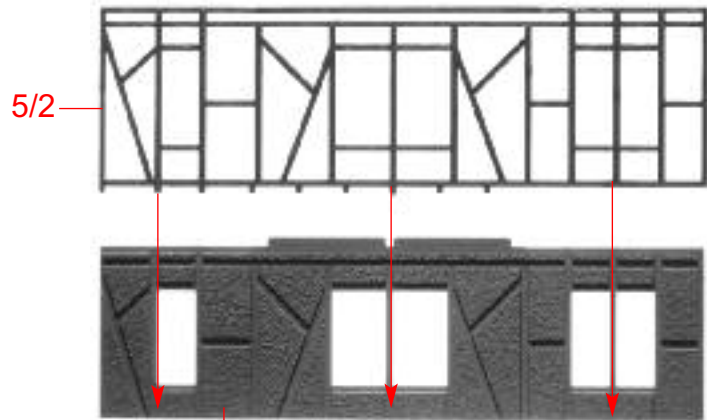
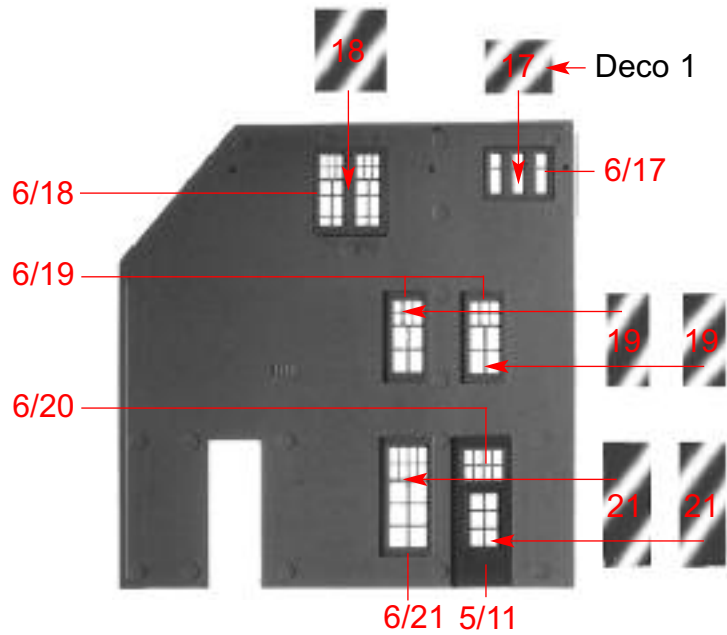

I

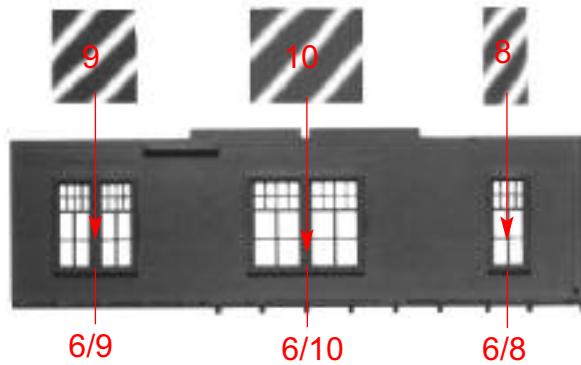

J



5

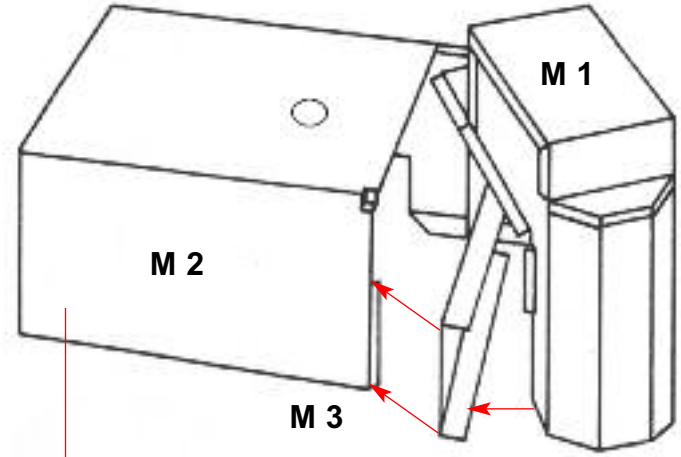
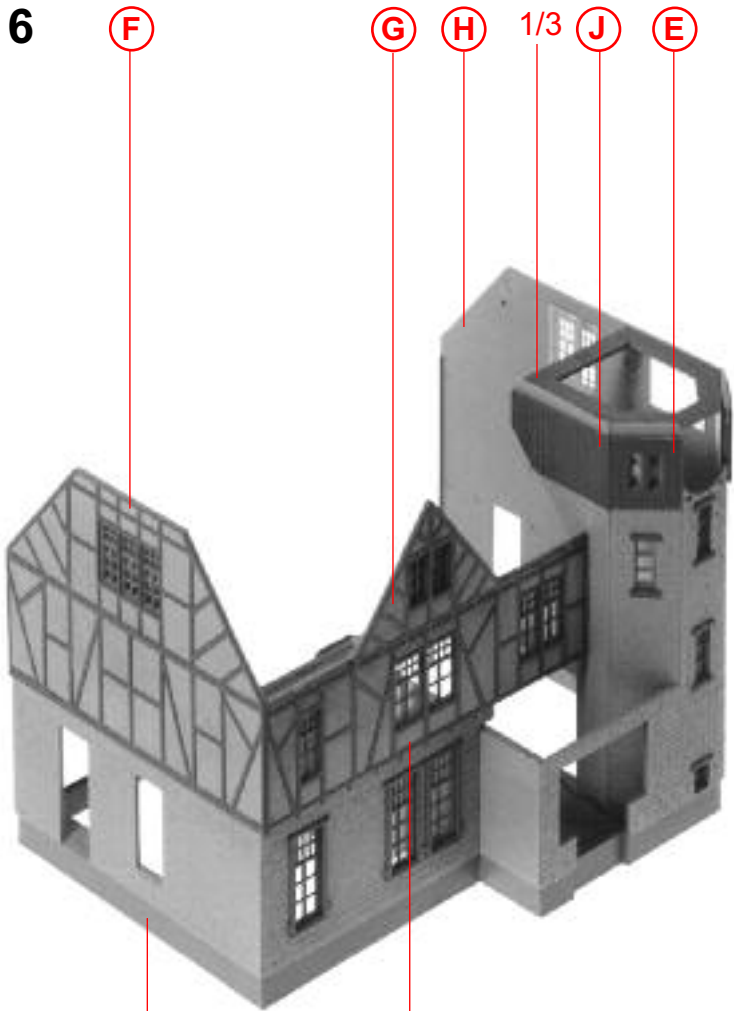

Papiermaske
 Papermask
 Masque
 Masker

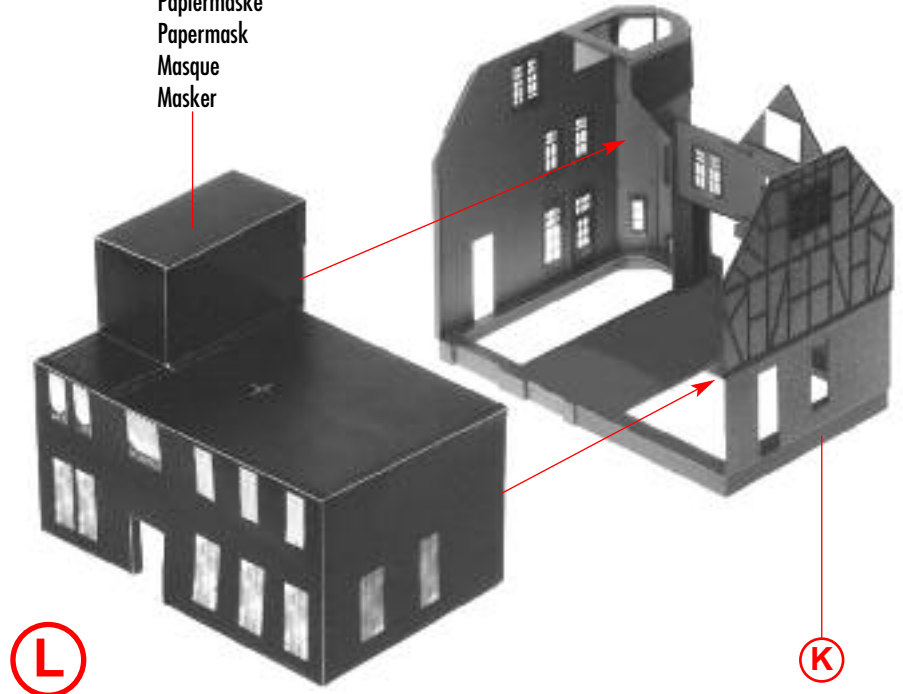

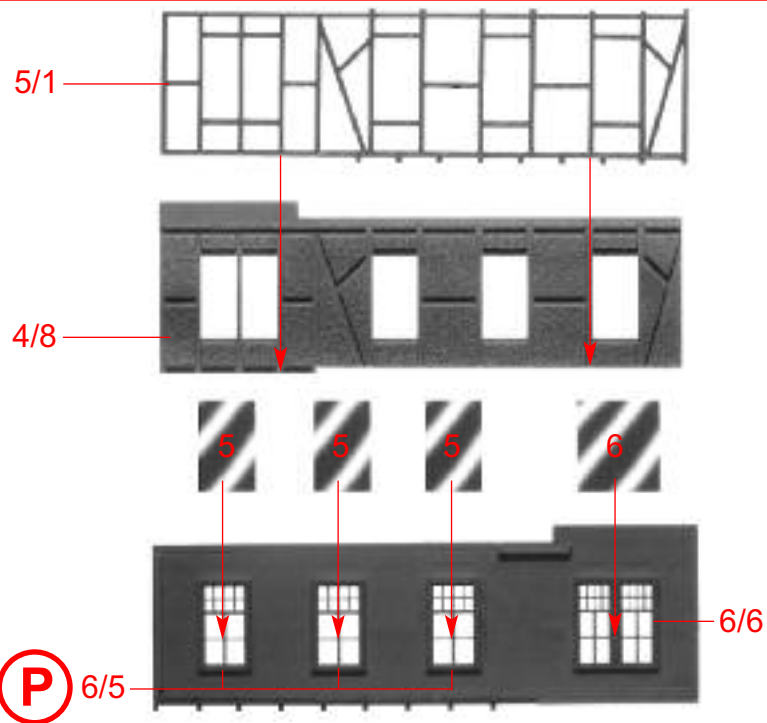
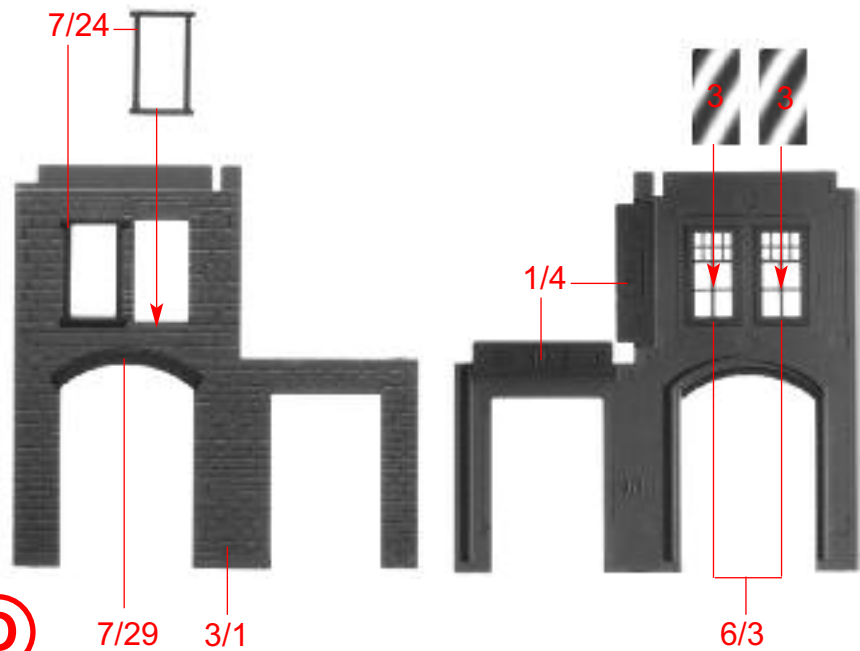
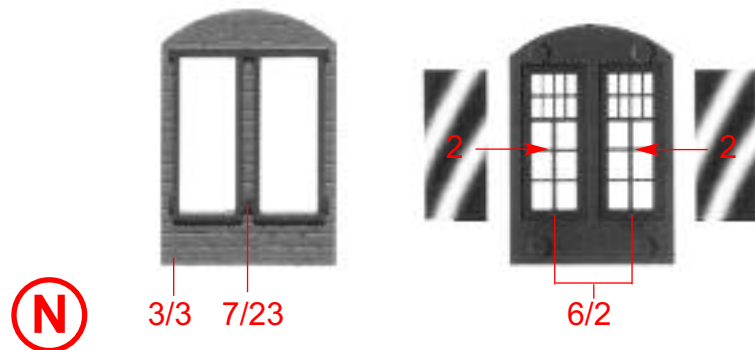
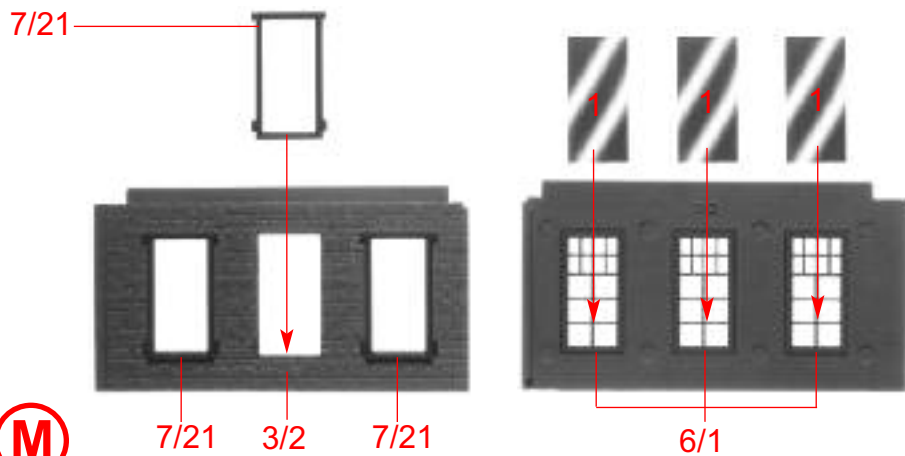

8

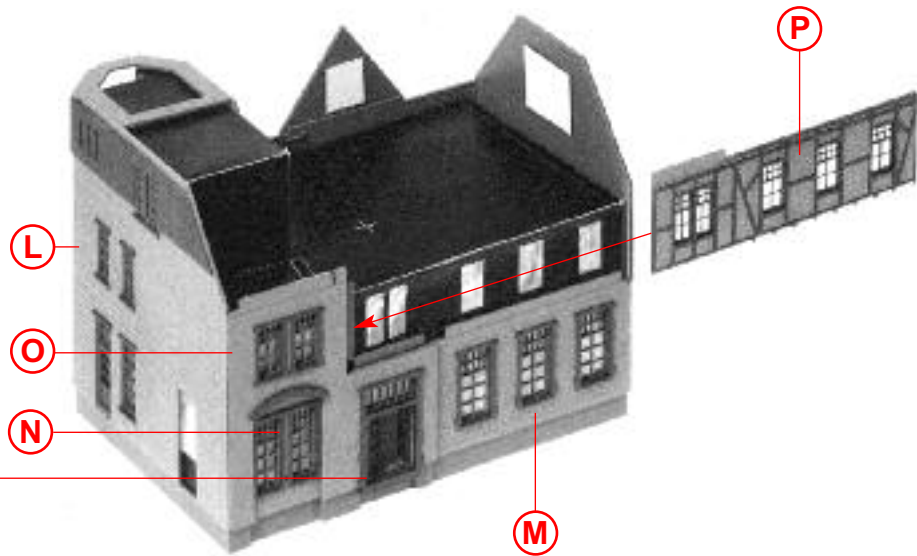
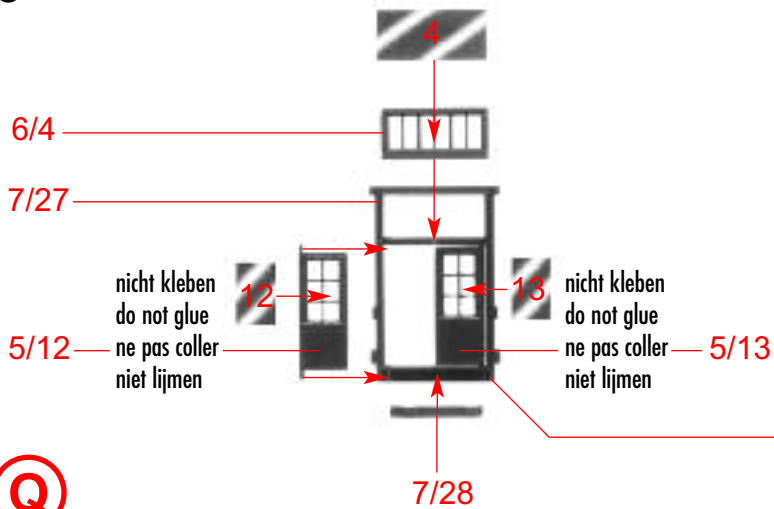

Q

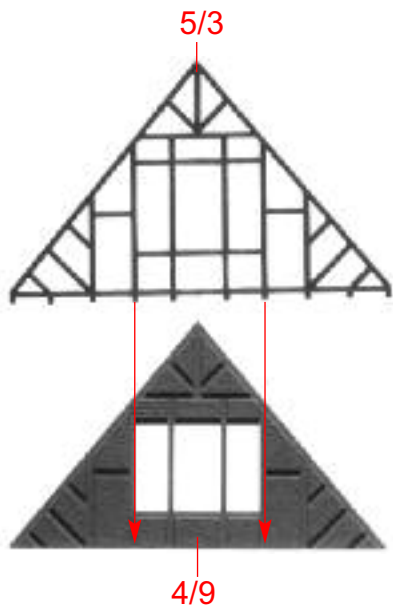

R

Deco 5

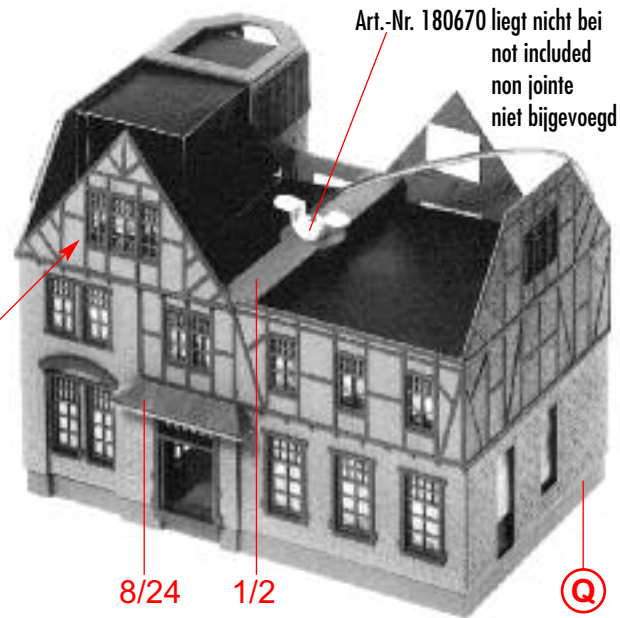
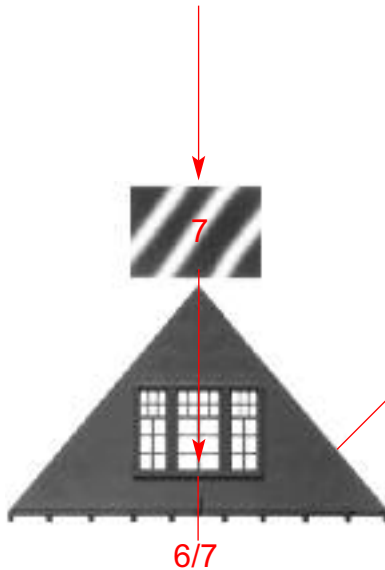

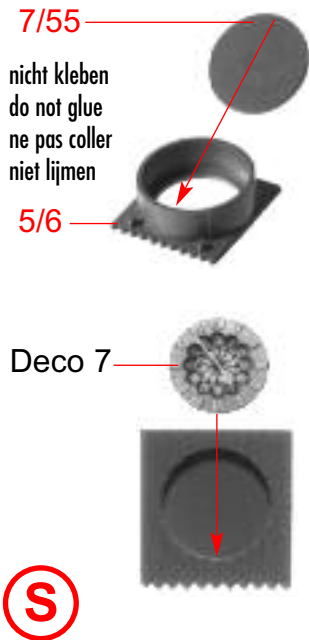

nicht kleben
do not glue
ne pas coller
niet lijmen

5/6

Deco 7

S

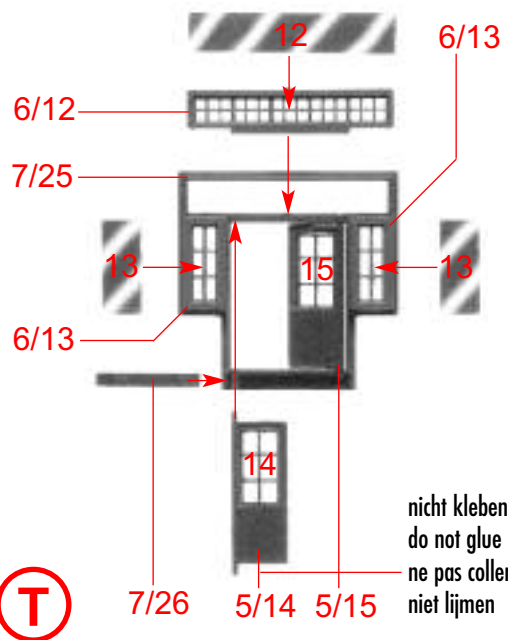

T

nicht kleben
do not glue
ne pas coller
niet lijmen

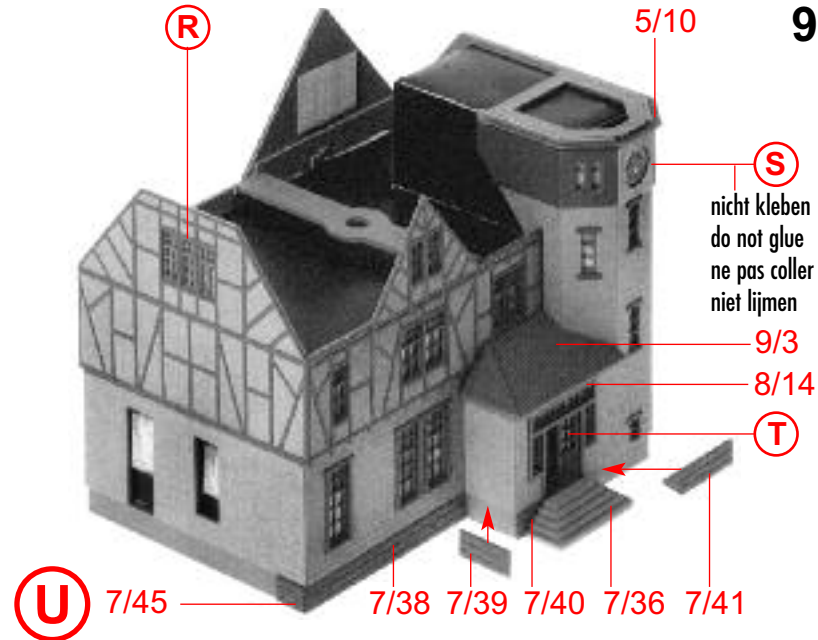

U

nicht kleben
do not glue
ne pas coller
niet lijmen

S

T

D Die Dachziegel können mit den beigegefügt Farbstiften (gelb und braun) zur feineren Gestaltung bemalt werden. Die zu colorierenden Ziegel sind optisch durch eine Hochglanzpolierung sichtbar. Drehen Sie die Dachteile im Licht leicht hin und her, bis das Muster erscheint. Beginnen Sie das Bemalen, der Skizze entsprechend, mit der braunen Farbe, danach mit dem gelben Stift. Ein einfacher Farbstrich genügt. Am leichtesten geht das Bemalen am unmontierten Spritzteil. Die Turmsegmente werden nur mit Gelb bemalt.

GB For enhanced appearance, the roof tiles can be painted with the included coloured pencils (yellow and brown). The tiles to be coloured are visible by their high mirror polish. Turn the roof parts exposed to light back and fourth until the pattern appears. Start painting as shown in the drawing with the brown pencil and than with the yellow pencil. A single colour stroke will be enough. Painting the unassembled moulded part is most convenient. Paint the tower segments with the yellow pencil only.

F Pour obtenir un profilage plus fin, les tuiles peuvent être peinturées avec les crayons de couleur joints (jaune et brun). Les tuiles à colorer sont rendues optiquement visibles par un poli spéculaire. Tournez les parties de toit légèrement en va et vient jusqu'à ce que le dessin apparait. Commencez la coloration en fonction du dessin avec le crayon à couleur brun, ensuite avec le crayon jaune. Un simple trait de couleur est suffisant. Le plus facile est de réaliser la coloration sur la pièce moulée par injection non montéc. Les segments de tour ne seront peints qu'avec le jaune.

NL Het dakpannenpatroon kan worden weergegeven met de verf van de bijgevoegde kleurstiften (geel en bruin). De te kleuren dakpannen zijn aan hun glans te herkennen. Als de dakdelen een beetje in het licht worden bewogen, wordt het patroon zichtbaar. Schilder eerst de dakpannen die bruin moeten worden zoals aangegeven in het schema en schilder daarna de gelen pannen. Een enkele verfstreek is voldoende. Schilder het dakdeel voordat u het vastlijmt. De torensegmenten worden alleen met geel beschilderd.

V

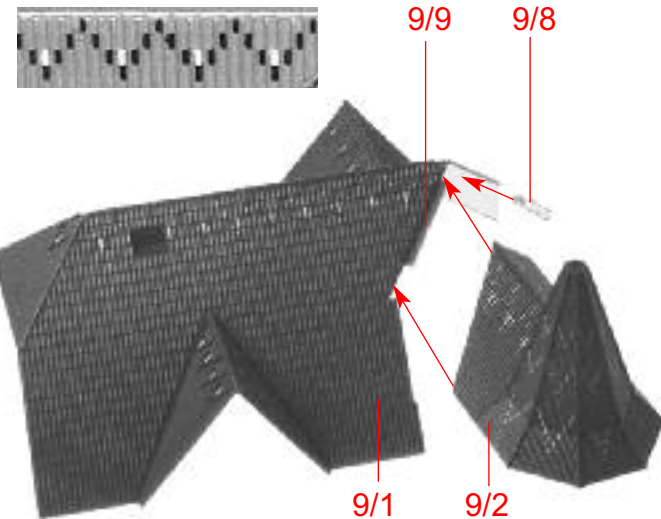

9/1

9/2

10

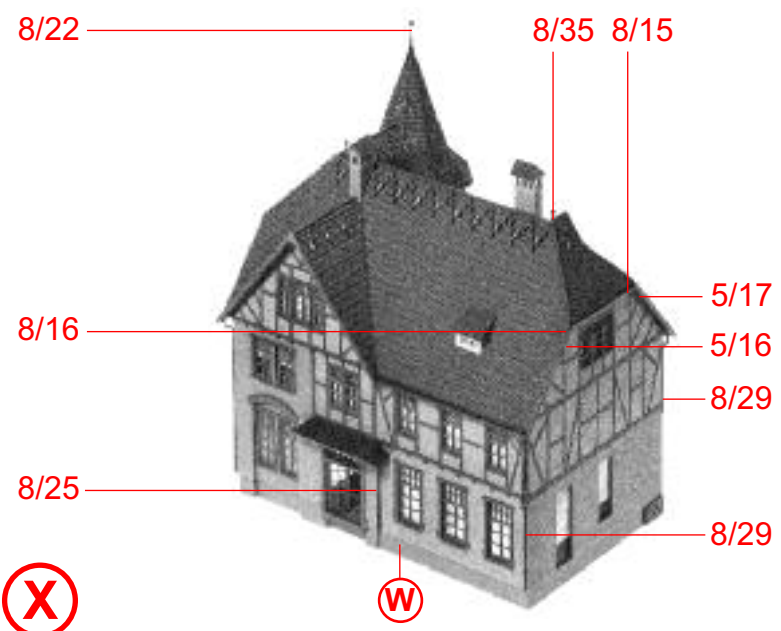
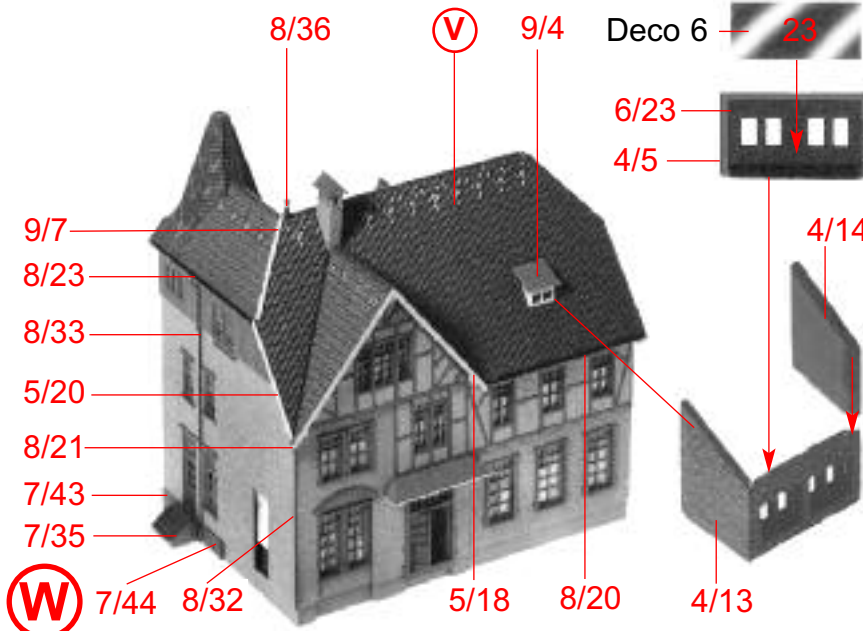
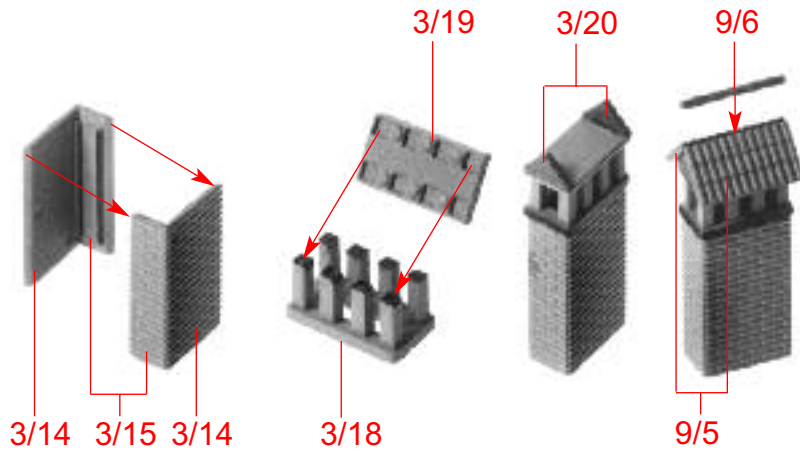
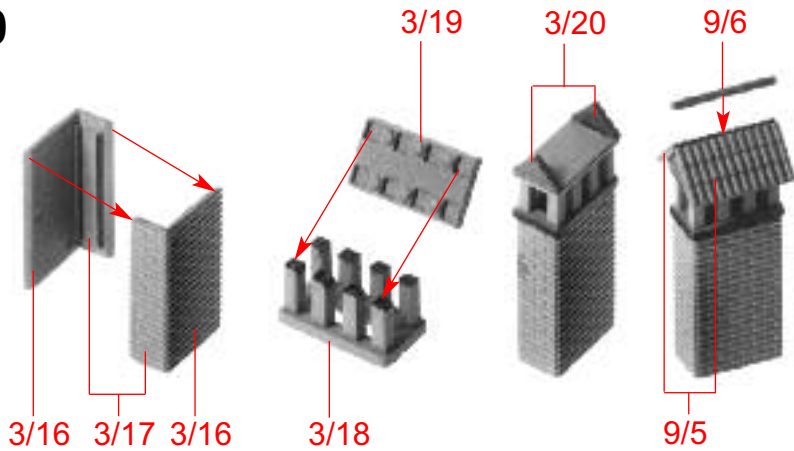

Y 14 x

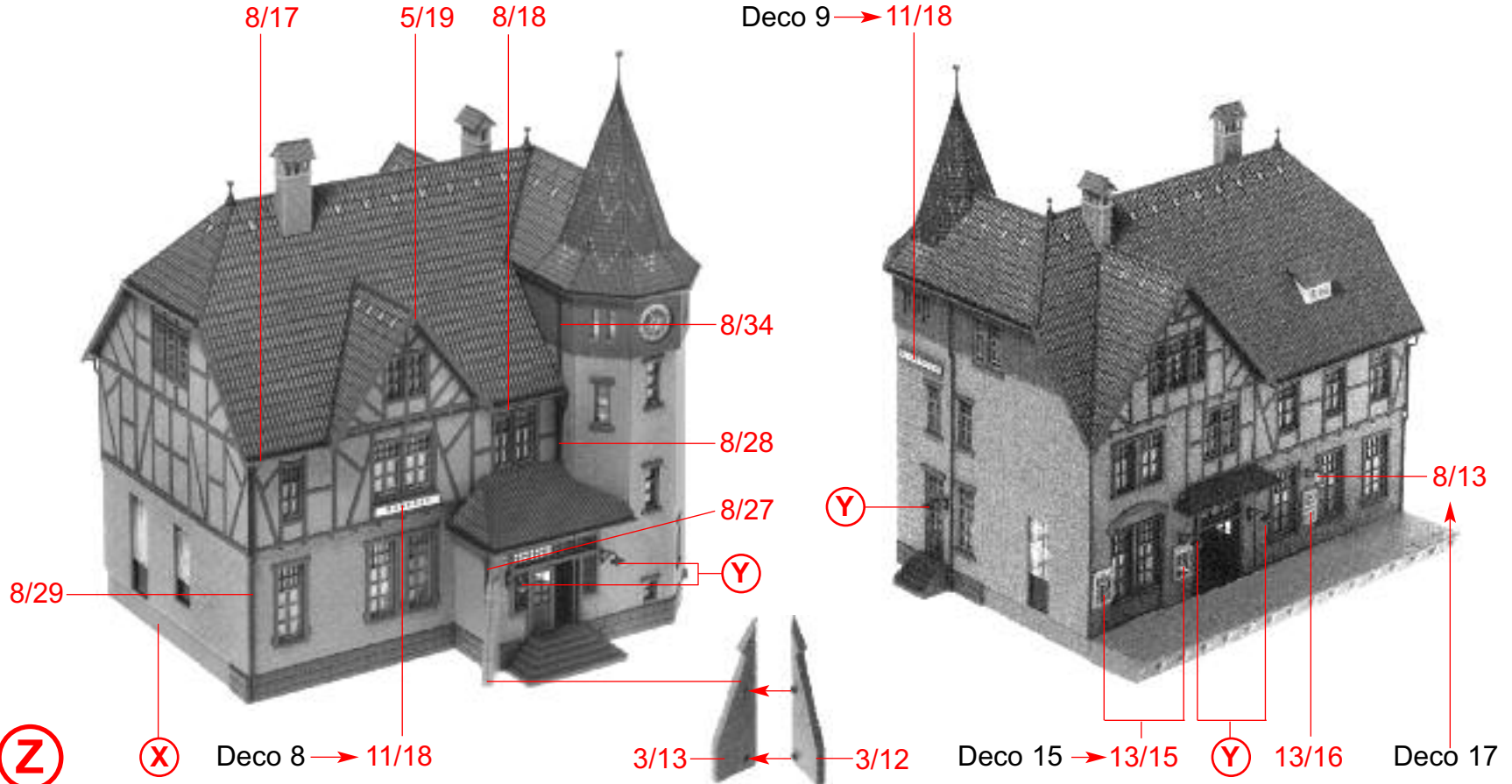
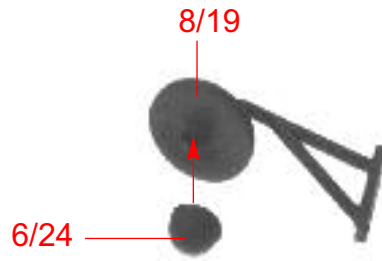

12

11/3



4/3

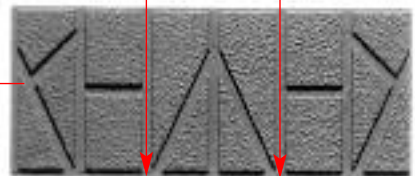

6/31

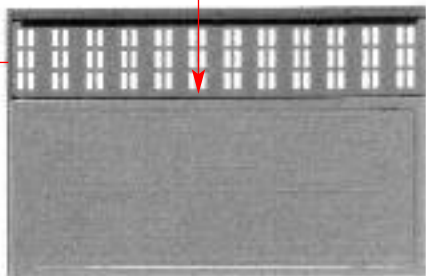
**(a)**

11/1

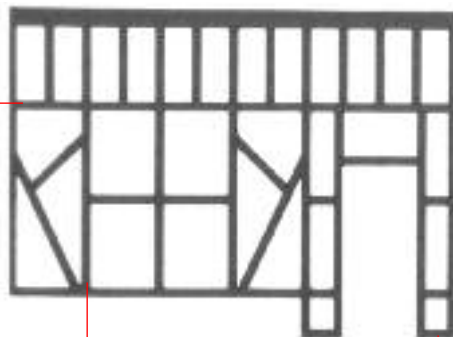

4/1



6/30

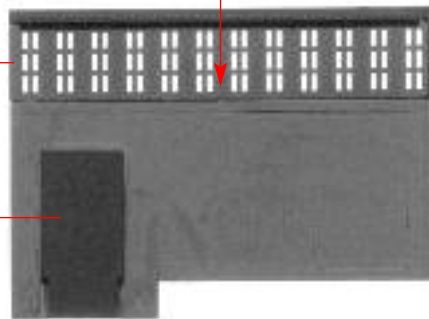

11/7

(b)

11/2



4/2



6/32

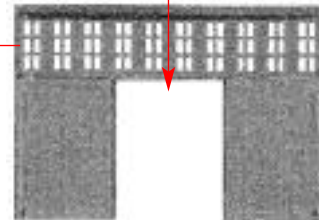

11/6

11/4

11/5

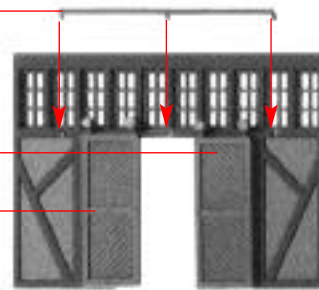
**(c)**

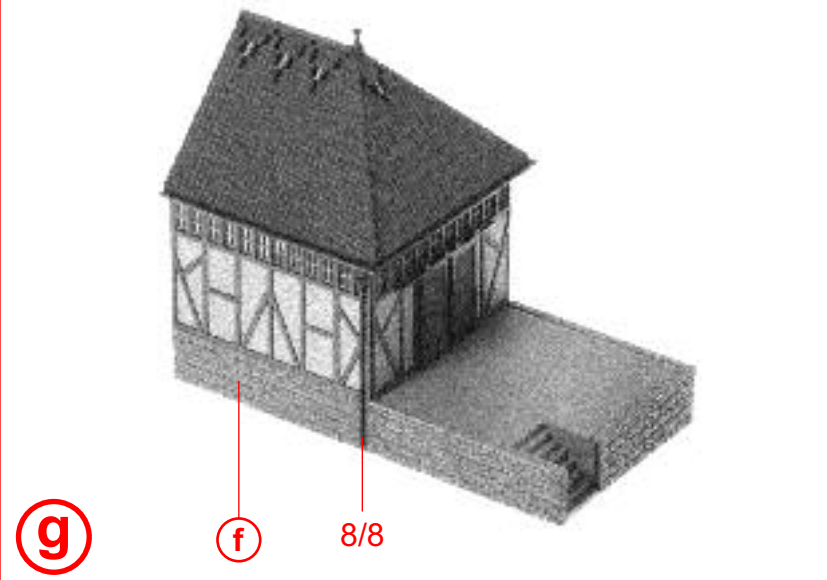
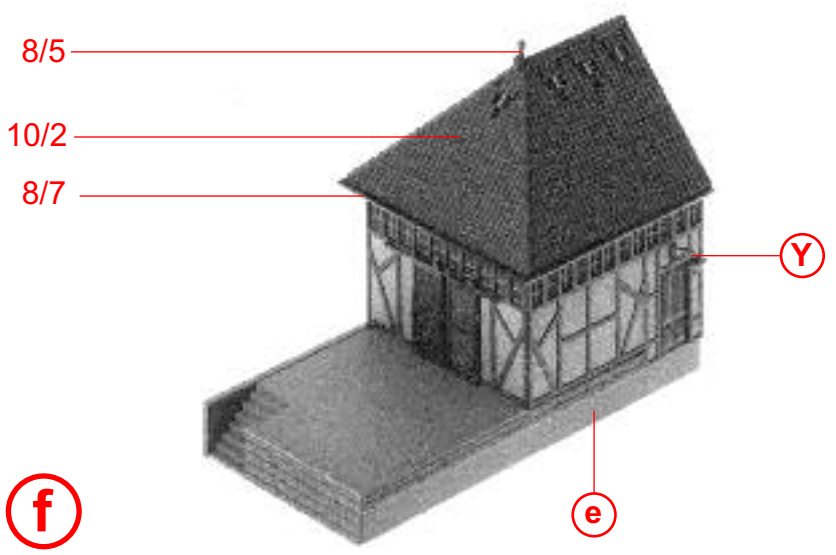
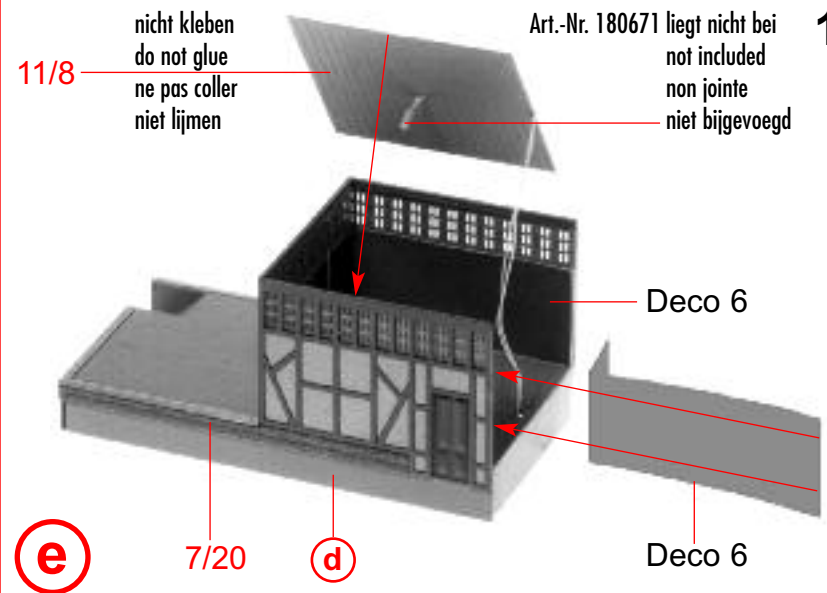
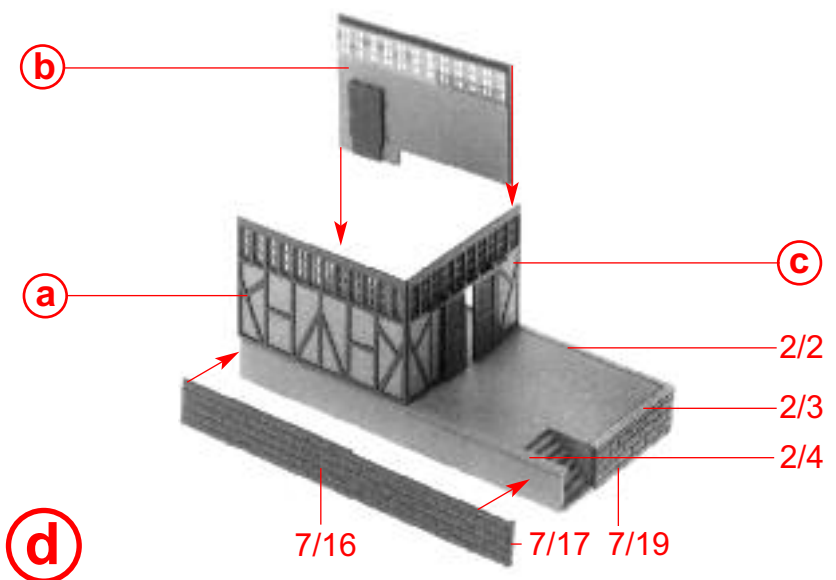

14

2/7

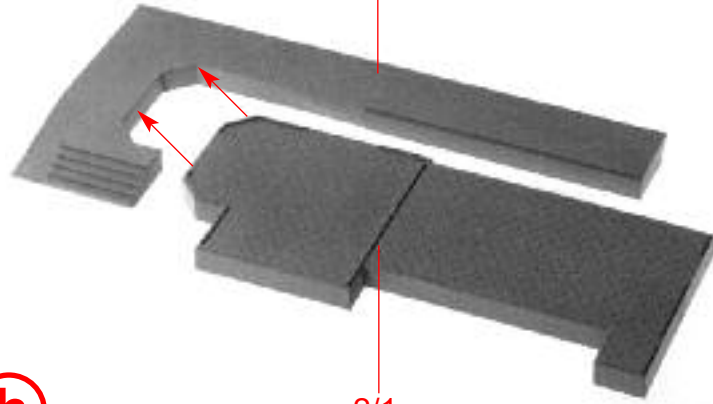

2/1

h

12/11 7/7 7/5 7/7

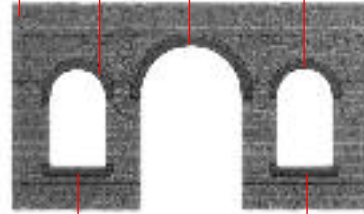

7/3

7/3

i

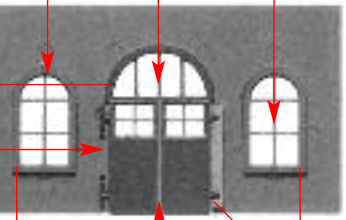

11/17

12/17

6/26

16

15

6/26

12/17

nicht kleben
do not glue
ne pas coller
niet lijmen

11/16

11/15

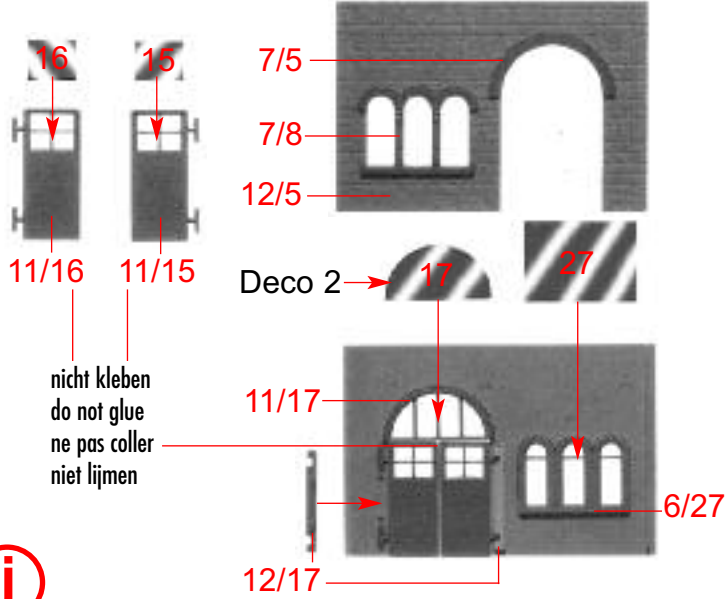

11/16

11/15

7/5

7/8

12/5

Deco 2

11/17

6/27

12/17

nicht kleben
do not glue
ne pas coller
niet lijmen

j

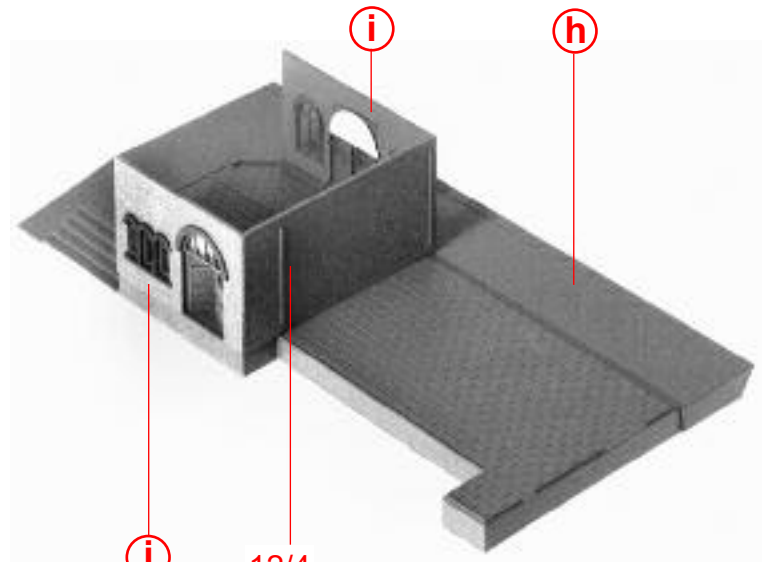

i

h

j

12/4

k

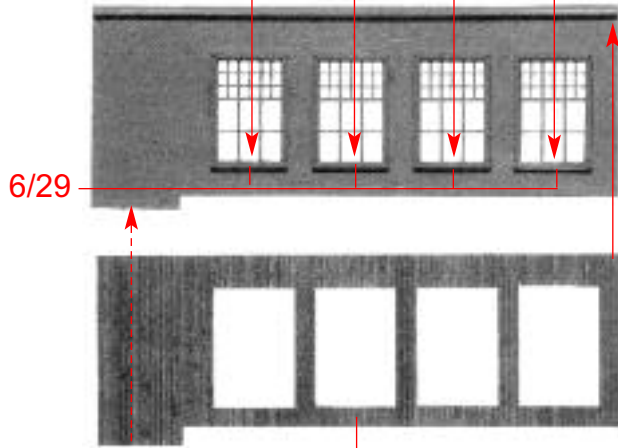
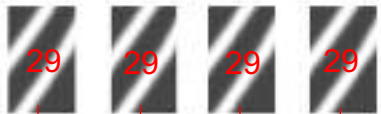
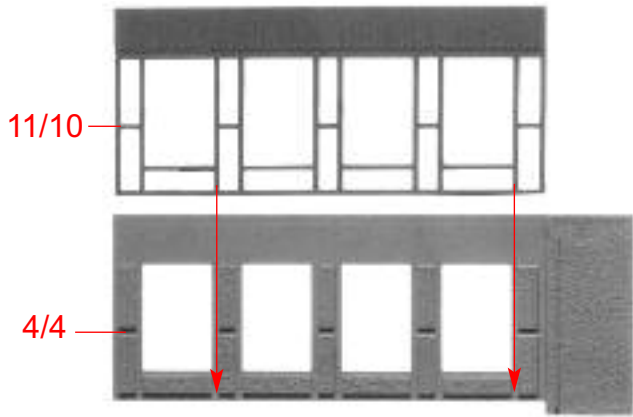

l

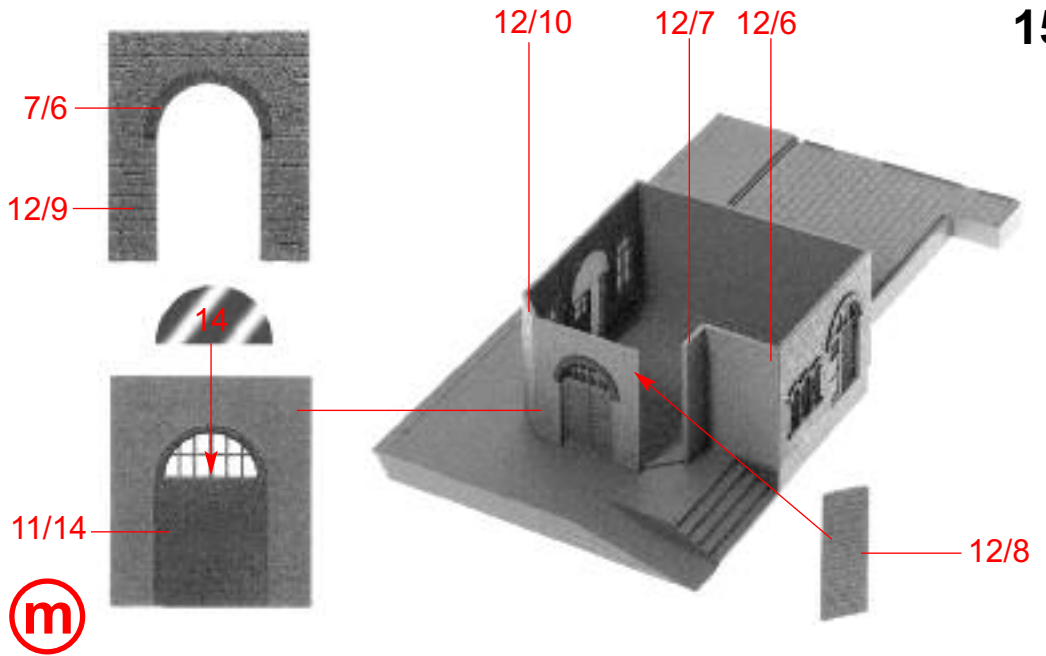

m

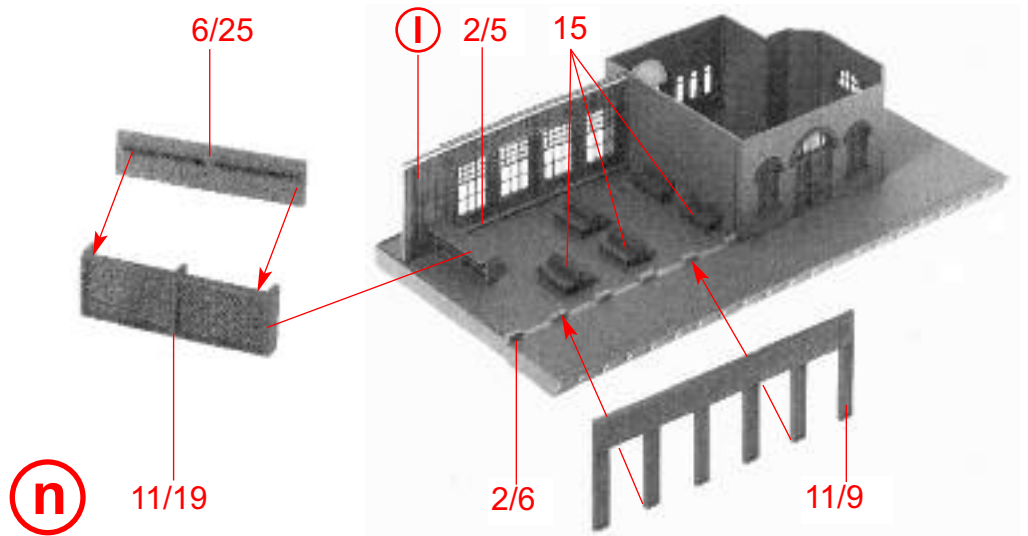

n

16

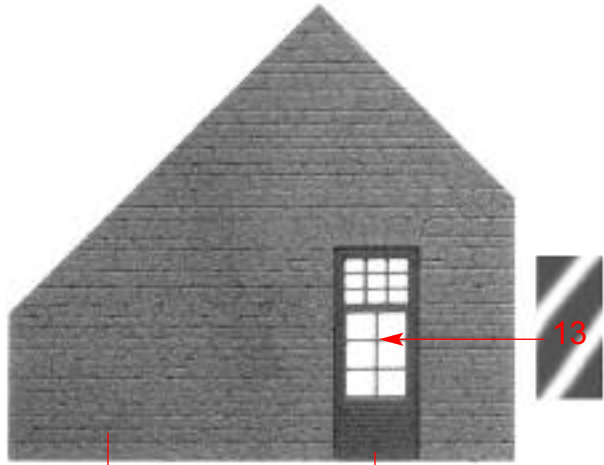

o

12/1

11/13

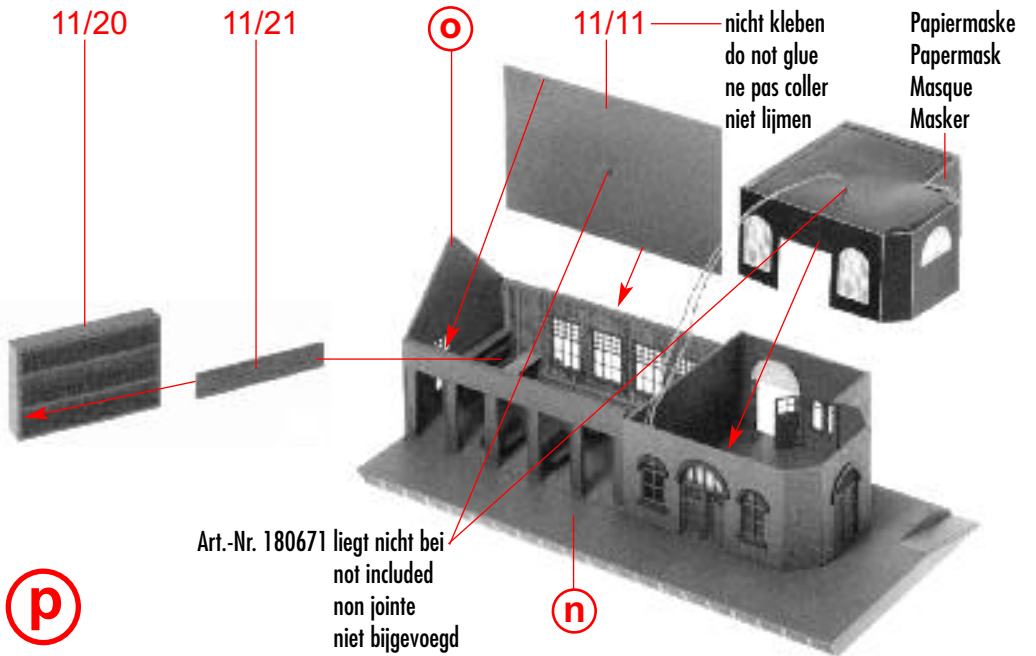

p

Art.-Nr. 180671 liegt nicht bei
not included
non jointe
niet bijgevoegd

n

Deco 4

28

7/1

7/1

q

12/2

6/28

Deco 5

12

7/2

r

12/3

11/2

s

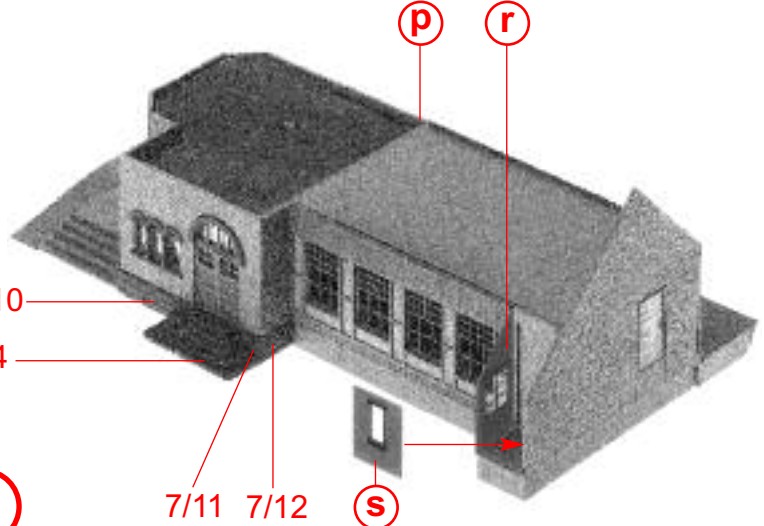

p

r

s

7/11

7/12

s

Deco 3

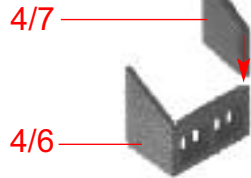
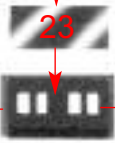

t 2 x

4/5 6/23

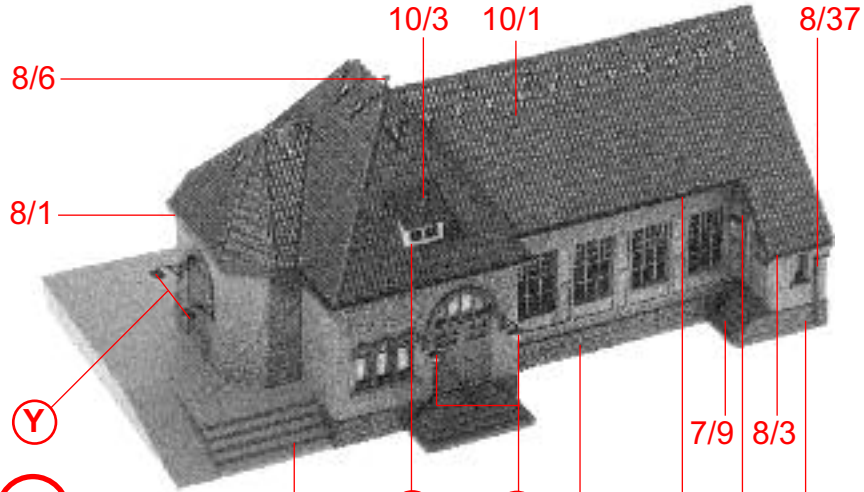

Y

u

q

t

Y

Y

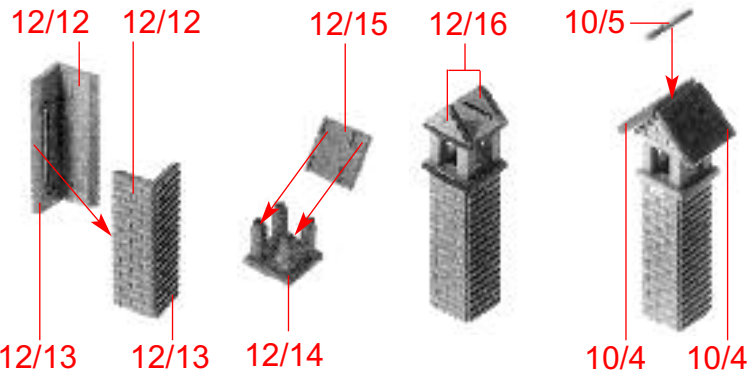

v

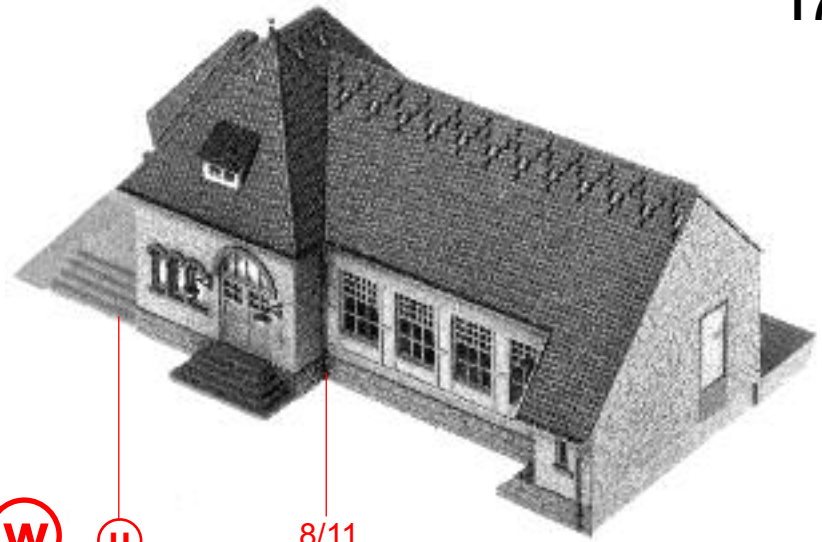

w

u

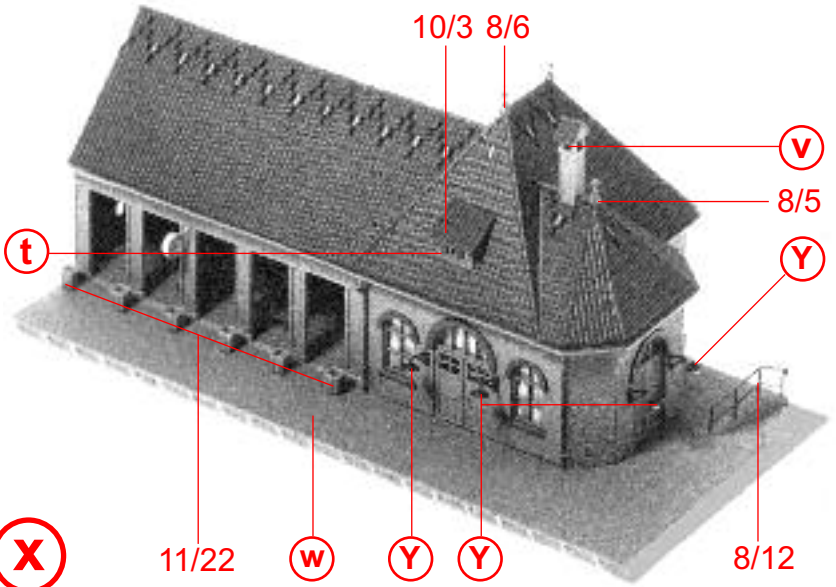

t

v

x

w

Y

Y

Y

18

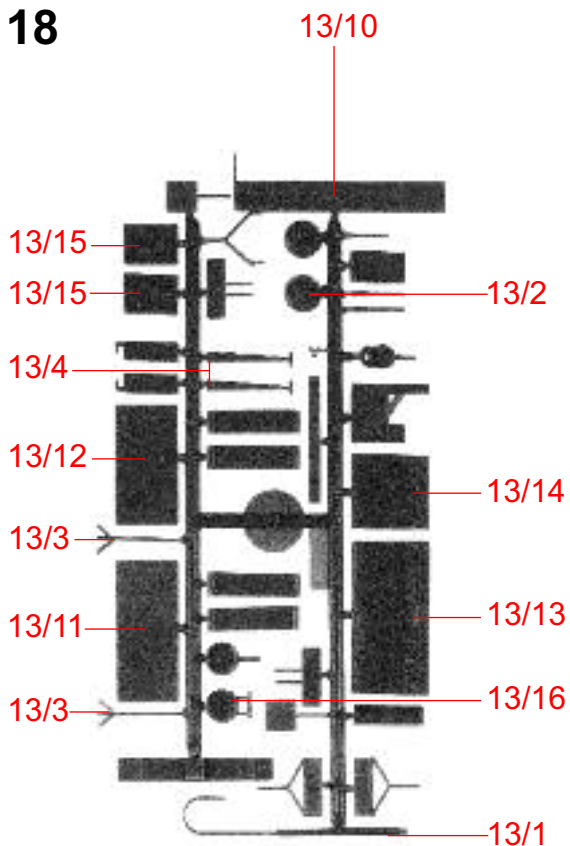

13

Deco 10

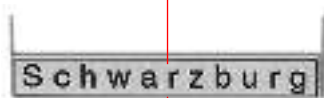

13/10

y

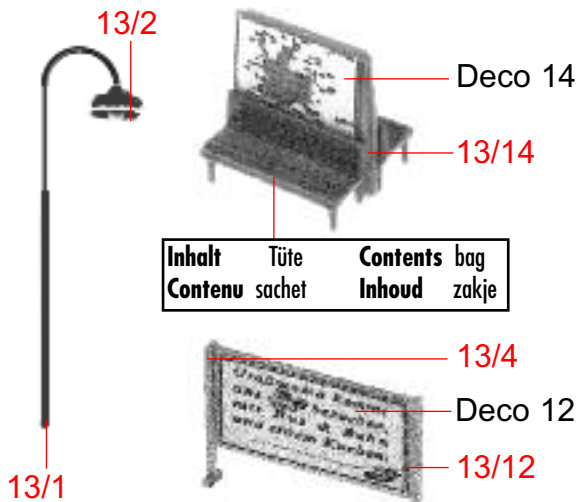

Inhalt	Tüte	Contents	bag
Contenu	sachet	Inhoud	zakje

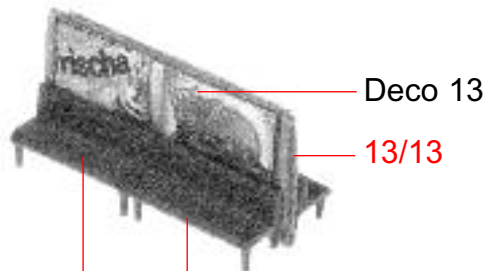
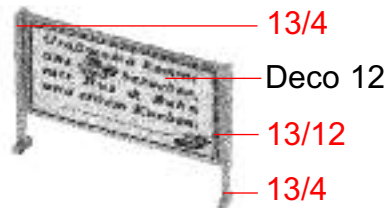

Inhalt	Tüte	Contents	bag
Contenu	sachet	Inhoud	zakje

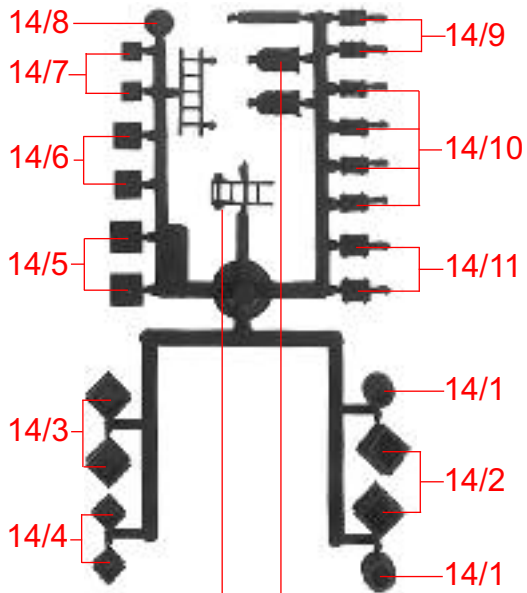
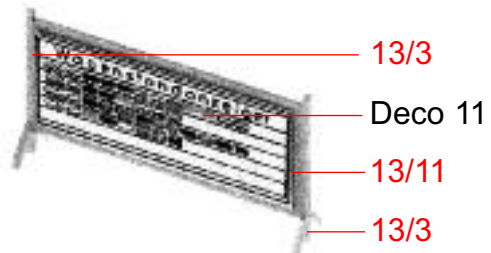

14

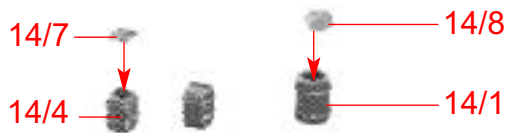
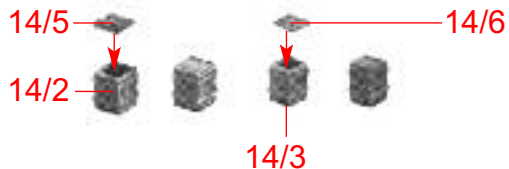

z

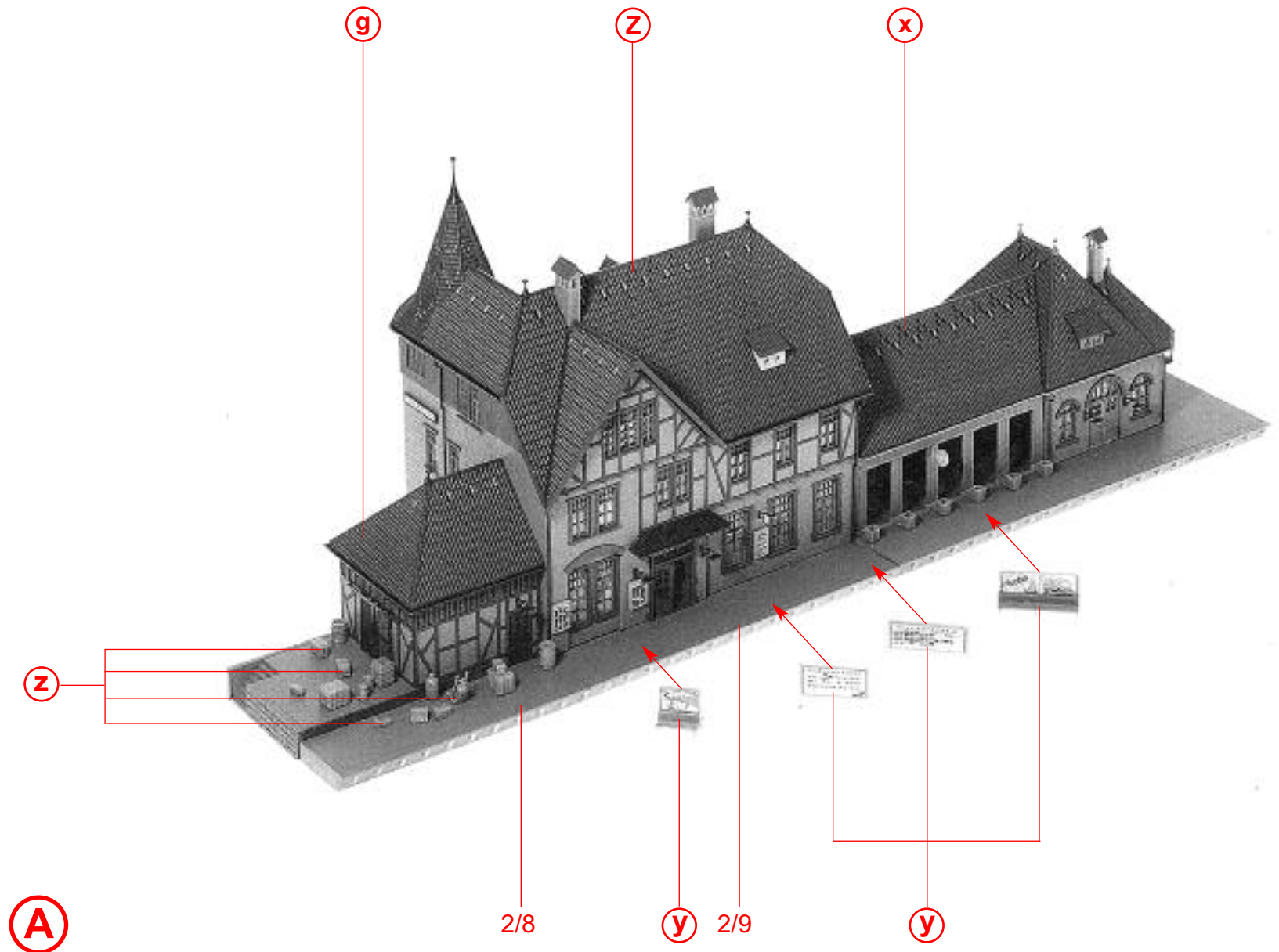

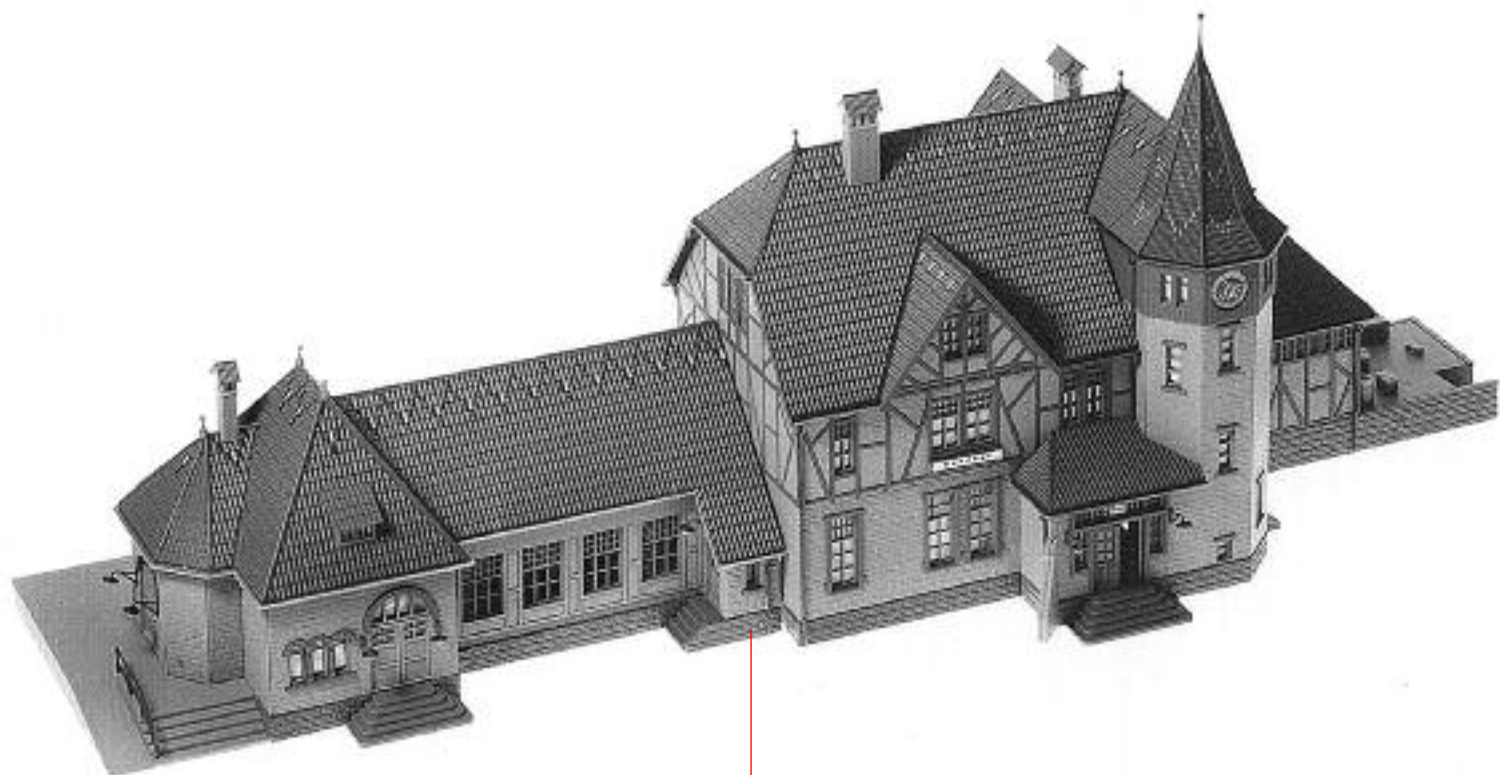
**B****A**